

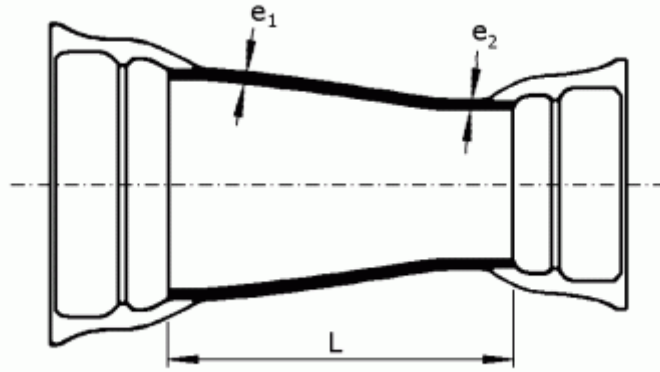

●Type T Double Socket Taper



K=12

Unit: mm

Larger Diameter		Smaller Diameter		L	Weight (kg)	Larger Diameter		Smaller Diameter		L	Weight (kg)
DN	e_1	dn	e_2			DN	e_1	dn	e_2		
100	7.2	80	7.0	90	8.5	700	14.4	350	10.2	780	203.0
150	7.8	80	7.0	190	13.5		14.4	400	10.8	680	201.0
	7.8	100	7.2	150	13.8		14.4	450	11.4	580	197.7
200	8.4	100	7.2	250	20.5		14.4	500	12.0	480	194.0
	8.4	150	7.8	150	21.0		14.4	600	13.2	280	178.0
250	9.0	150	7.8	250	29.0	800	15.6	400	10.8	880	270.4
	9.0	200	8.4	150	29.0		15.6	450	11.4	780	267.4
300	9.6	150	7.8	350	39.5		15.6	500	12.0	680	264.2
	9.6	200	8.4	250	39.5		15.6	600	13.2	480	252.0
	9.6	250	9.0	150	38.5		15.6	700	14.4	280	229.0
350	10.2	200	8.4	360	52.0	900	16.8	450	11.4	980	348.5
	10.2	250	9.0	260	51.0		16.8	500	12.0	880	345.8
	10.2	300	9.6	160	49.5		16.8	600	13.2	680	335.1
400	10.8	200	8.4	460	70.5		16.8	700	14.4	480	318.0
	10.8	250	9.0	360	66.0		16.8	800	15.6	280	288.0
	10.8	300	9.6	260	64.0	1000	18.0	500	12.0	1080	440.0
	10.8	350	10.2	160	62.0		18.0	600	13.2	880	430.4
450	11.4	250	9.0	460	87.5		18.0	700	14.4	680	414.5
	11.4	300	9.6	360	86.7		18.0	800	15.6	480	392.0
	11.4	350	10.2	260	84.9		18.0	900	16.8	280	354.0
	11.4	400	10.8	160	81.9	1100	19.2	600	13.2	1080	545.6
500	12.0	250	9.0	560	108.1		19.2	700	14.4	880	530.7
	12.0	300	9.6	460	107.4		19.2	800	15.6	680	509.0
	12.0	350	10.2	360	98.0		19.2	900	16.8	480	479.4
	12.0	400	10.8	260	94.0		19.2	1000	18.0	280	441.7
	12.0	450	11.4	160	90.5	1200	20.4	600	13.2	1280	671.9
600	13.2	300	9.6	660	156.1		20.4	700	14.4	1080	658.5
	13.2	350	10.2	560	154.8		20.4	800	15.6	880	638.0
	13.2	400	10.8	460	142.0		20.4	900	16.8	680	609.6
	13.2	450	11.4	360	138.5		20.4	1000	18.0	480	570.0
	13.2	500	12.0	260	131.0		20.4	1100	19.2	280	525.9